



# XFT133

Project \_\_\_\_\_

Item \_\_\_\_\_

Quantity \_\_\_\_\_

Date \_\_\_\_\_

**Model**  
LINEMISS™

Convection oven	Electric
4 trays 460x330	Drop down opening
Knob	
Voltage: 220-240V 1N~	

### Description

Convection oven with humidity, analogical control and 304 stainless steel cooking chamber. Time, temperature, steam percentage and 2 fan speeds function. Ideal for all baking processes of fresh and frozen bakery products. The AIR.Plus technology guarantees perfect cooking uniformity on all baking trays.



### Standard cooking features

#### Manual cooking

- **Temperature:** 80 °C – 260 °C
- Convection and humidity cooking starting from 80 °C

### Advanced and automatic cooking features

#### Unox Intensive Cooking

- **DRY.Plus:** rapidly extracts humidity from the cooking chamber
- **STEAM.Plus:** creates instant humidity
- **AIR.Plus:** multiple fans with reverse gear

#### Key features

- Rounded baking chamber made of high-resistance AISI 304 steel
- Double glass
- Cooking chamber lighting through LED lights embedded in the door
- Baking chamber with chrome-plated steel rack rails
- Fan system and high-performance circular heating elements



# XFT133

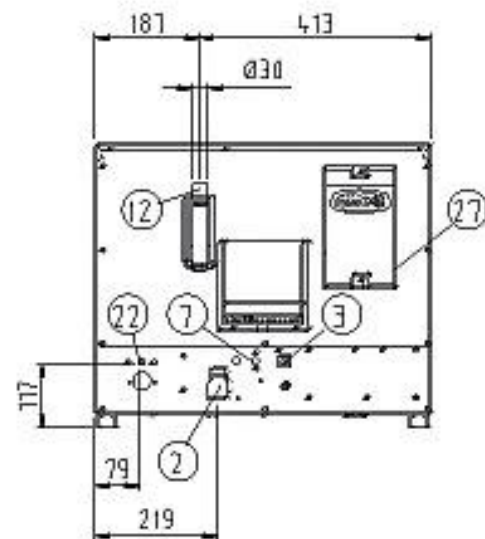
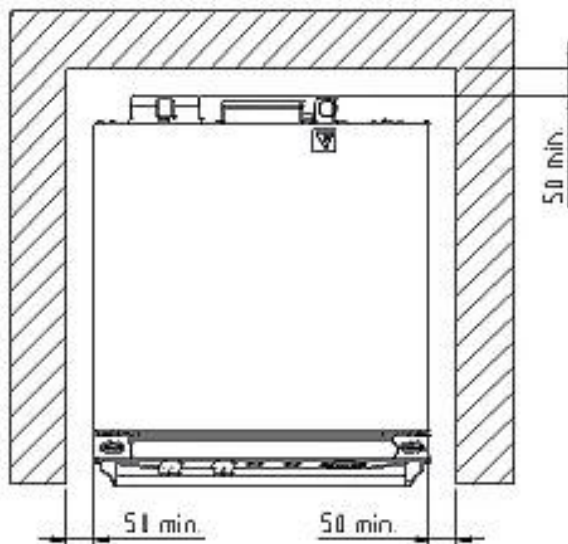
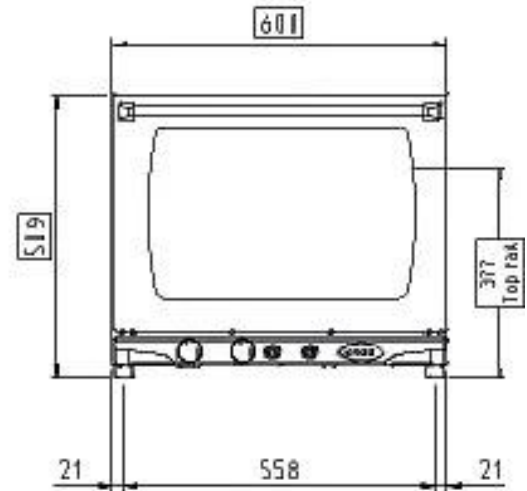
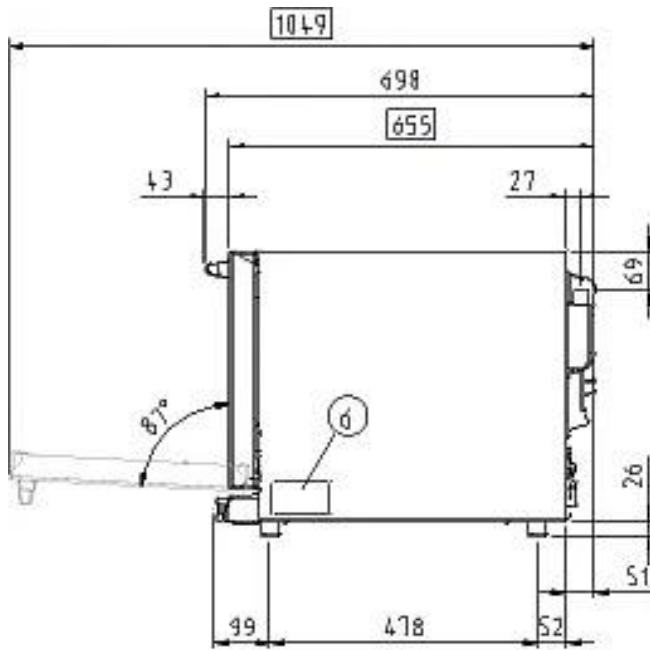

## Dimensions and weight

Width	600 mm
Depth	655 mm
Height	509 mm
Net weight	31 kg
Tray pitch	75 mm

## Connection positions

2	Terminal board power supply
3	Unipotential terminal
6	Technical data plate
7	Safety thermostat
12	Hot fumes exhaust chimney
22	Water pump inlet

27	Cooling air outlet
----	--------------------



# XFT133

Power supply

Water connection

Installation requirements

Accessories

## Electrical power supply

### STANDARD

Voltage	220-240 V
Phase	~1PH+N+PE
Frequency	50 / 60 Hz
Total power	3 kW
Max Amp draw	13 A
Required breaker size	16 A
Power cable requirements*	3G x 1,5 mm <sup>2</sup>
Plug	Schuko

\*Recommended size - observe local ordinance.

## Accessories

- **LIEVOX:** Proofer equipped with sensors capable to control and intervene automatically on the leavening process
- **Stand:** the multifunctional support ideal for storing trays safely and placing your oven at the perfect height to work
- **Baking Essentials:** special trays
- **SPRAY&Rinse:** Practical spray detergent to manually clean all kinds of oven. It degreases and removes all kind of dirt
- **PURE / PURE.XL:** resin-based filtering system that eliminates from the water all substances that contribute to the formation of limescale inside the oven cooking chamber

## Water Supply

USING A WATER SUPPLY THAT DOES NOT MEET UNOX'S MINIMUM WATER QUALITY STANDARDS WILL VOID ANY WARRANTY.

It is the responsibility of the purchaser to ensure that the incoming water supply is compliant with the listed specifications through adequate treatment measures.

Drinking water inlet: 3/4" NPT\*, line pressure:

**Line pressure:** 22 to 87 psi; 1.5 to 6 Bar (29 psi; 2 Bar recommended)

### Inflow water specifications

**Free chlorine** ≤ 0.5 ppm

**Chloramine** ≤ 0.1 ppm

**pH** 7 - 8.5

**Electrical conductivity** ≤ 1000 μS/cm

**Total hardness** ≤ 30° dH

### Steam circuit: inflow water specifications

**Chlorides** ≤ 120 ppm

**Total hardness** ≤ 8 °dH

To avoid the formation of limescale the incoming water must have total hardness ≤ 8°dH.

## Installation requirements

Installations must comply with all local electrical systems, particularly as for minimum wire gauge required for field connection, hydraulic and ventilation supply. Exhaust and fume analysis must be performed in case of gas ovens.

Register to DDC Service to access data and product specifications.

[www.ddc.unox.com](http://www.ddc.unox.com)