

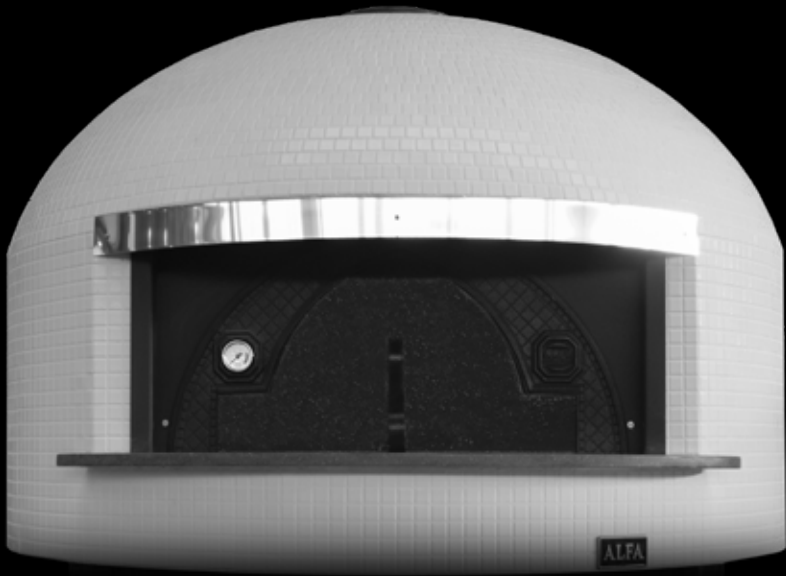

USER MANUAL
NAPOLI SERIES



USER MANUAL

Download the complete user manual



Alfa Forni participates in the SAVE THE PLANET initiative; that's why the manual has been printed only in English. To download the other languages, scan the QR code or click the link below.



Alfa Forni partecipa all'iniziativa SAVE THE PLANET, per questo il manuale è stato stampato esclusivamente in lingua inglese. Per scaricare le altre lingue scansionare il QRcode oppure digita il link qui sotto.



Alfa Forni nimmt an der SAVE THE PLANET-Initiative teil. Die gedruckte Anleitung ist deswegen nur auf Englisch verfügbar. Um die anderen Sprachen herunterzuladen, scannen Sie den QR-Code oder geben Sie den Link hier unten ein



Alfa Forni participe à l'initiative SAUVER LA PLANÈTE et pour cela le manuel à été imprimé seulement en anglais. Pour télécharger les autres langues, flashez le code QR ou cliquez sur ce lien.



Alfa Forni participa en la iniciativa SALVAR EL PLANETA, por eso el manual fue publicado solo en inglés. Para descargar los otros idiomas escanea el código QR o haz clic aquí.

RETAIN THIS MANUAL FOR FUTURE REFERENCE



DOWNLOAD USER MANUAL

www.alfaforni.com/user-manual-napoli.php

ALWAYS READ THE COMPLETE USER MANUAL.

Further copies of this manual are available at www.alfaforni.com

TABLE OF CONTENTS

FIRST IGNITIONS.....	4
WARNINGS	6
BASE ASSEMBLY	10
FLAME ADJUSTMENT.....	14
POSITIONING	20
GAS BURNER ASSEMBLY.....	21
OVEN INSTALLATION.....	22
WOOD IGNITION	24
GAS IGNITION.....	25
SETTINGS	26
GAS BURNER UNLOCKING.....	29
34 KW BURNER.....	30
CLEANING AND MAINTENANCE.....	38
WARRANTY	42

PAY ATTENTION DURING THE FIRST IGNITION

WARNING: Before lighting the oven, follow the instructions below:

- Do not use flammable liquids or other fuels to ignite the oven.
- Ensure there are no flammable materials near the oven and that the minimum installation distances are respected.
- Use particular caution during the first ignitions to avoid thermal shock, which could damage the refractory stone.
- Carefully read the following information to ensure proper installation and optimal operation of the oven.

INITIAL IGNITIONS

After installation, wait 3 days before lighting the oven. The first few ignitions are intended to allow all parts of the oven to dry out from the moisture generated during manufacturing.

FIRST DAY

Use extreme caution during the first ignition. Do not exceed 100 °C and maintain this temperature for as long as possible (at least 50 to 60 minutes). It is recommended to use a flame produced by small twigs.

SECOND DAY

Use extreme caution during the second ignition. Do not exceed 100 °C and maintain this temperature for as long as possible (at least 50 to 60 minutes). It is recommended to use a flame produced by small twigs.

THIRD DAY

Do not exceed 200 °C during the third ignition and maintain this temperature for as long as possible (at least 50 to 60 minutes). It is recommended to use wood cut into small pieces.

FOURTH DAY

Reach a maximum temperature of 300 °C using small pieces of wood and maintain this temperature for as long as possible.

FIFTH DAY

On the fifth day, it is possible to light the oven and start baking pizzas: the refractory material will be completely dry.



WARNING: During the first few days of ignition, water may leak from the oven structure; this is normal and is due to possible moisture inside the refractory stone.

USE CAUTION DURING THE FIRST IGNITION

Before starting the burner, it is necessary to perform the appropriate preliminary checks to avoid malfunctions or damage to the machine itself:

- Check that the oven door is open;
- Check that all gas system valves are open;
- Check the correct connection of all electrical conductors;
- Check that the protective steel cap above the burner has been removed;
- Check that there are no leaks in the gas system;
- Check the gas pressure at the burner's main outlet.

INITIAL IGNITIONS

After installation, wait 3 days before lighting the oven. The first few days of ignition are meant to dry out all parts of the oven from the moisture generated during production.

FIRST DAY

Use extreme caution during the first ignition. Do not exceed 100 °C and maintain this temperature for as long as possible (at least 50 to 60 minutes).

SECOND DAY

Use extreme caution during the second ignition. Do not exceed 100 °C and maintain this temperature for as long as possible (at least 50 to 60 minutes).

THIRD DAY

Do not exceed 200 °C during the third ignition and maintain this temperature for as long as possible (at least 50 to 60 minutes).

FOURTH GIORNO

Reach a maximum temperature of 300 °C using small pieces of wood and maintain this temperature for as long as possible.

FIFTH DAY

On the fifth day, you can light the oven and start baking pizzas; the refractory material will be completely dry.



WARNING: During the first few days of ignition, water may leak from the oven structure; this is normal and is due to possible moisture inside the refractory stone.

WARNINGS

PLEASE KEEP THIS MANUAL FOR FUTURE REFERENCE
Digital copies of this manual are available at www.alfaforni.com

PLEASE READ THE FOLLOWING INFORMATION CAREFULLY FOR PROPER INSTALLATION AND APPROPRIATE USE OF THE OVEN. THIS APPLIANCE, IF NOT INSTALLED AND USED CORRECTLY, CAN CAUSE A FIRE. TO REDUCE THE RISK OF FIRE, FOLLOW THE INSTRUCTIONS AND USE MATERIALS SPECIFICALLY DESIGNED TO WITHSTAND HIGH TEMPERATURES.

- Cracks may appear inside and outside the refractory materials of the oven due to thermal shock; these do not affect the proper functioning of the appliance.
- In case of long periods of inactivity, follow the instructions as if it were the first use
- The oven door is an effective temperature regulator: by opening and closing it, you can control the heat.
- During use, refractory ovens can become very hot.
- Use tools and utensils resistant to high temperatures.
- For safety reasons, keep the oven out of reach of children and pets.
- Place the oven on a flat surface, protected from wind or strong drafts.
- Sparks may come out from the oven opening: avoid placing flammable liquids nearby
- Do not touch the smoke exhaust duct or the door while the oven is in use to avoid burns.
- Do not use the oven if it is broken or malfunctioning.
- Hold the door handle when opening and closing.
- The oven's color may change due to temperature.
- Do not use water to extinguish the fire.
- Do not use flammable liquids near the oven.
- Do not paint the oven or attach objects to it.
- Do not use fuels other than those recommended.
- Do not light the oven abruptly to avoid damage to the refractory materials.
- At 100 °C, water or moisture inside the oven turns into steam. During this process, the volume of water multiplies by 30, which can severely damage the refractory materials if ignition is not gradual.
- Do not lean over the oven during ignition: keep your face and body away from the oven opening.
- Do not leave the appliance unattended while cooking foods that release fats or oils; they could catch fire.
- Do not block the ventilation openings.
- Wear heat-resistant gloves while using the oven.

WARNINGS

FOR WOOD-FIRED OR HYBRID OVENS ONLY



Do not throw the logs into the fire; instead, gently place them on top.
Do not start a fire that is too large or extends beyond the oven opening.

Do not use any fuel other than firewood.

WARNINGS

FOR GAS OVENS ONLY

GAS LEAKS CAN CAUSE FIRES AND EXPLOSIONS AND CAN RESULT IN SEVERE PROPERTY DAMAGE, SERIOUS INJURY, OR DEATH.

WHAT TO DO IN CASE OF GAS ODOR:

1. Shut off the gas supply
2. Extinguish any open flames
3. Open the oven door
4. Call a qualified gas technician

WARNING: This oven can be converted from natural gas to LPG and vice versa using the appropriate kit provided by Alfa Forni; the conversion must be carried out by specialized technicians using Alfa materials, otherwise the warranty will no longer be valid.

The product must be installed by qualified personnel.

- If the gas oven is not in use, shut off the gas supply.
- Follow the instructions to connect the gas pressure regulator.
- If the oven remains unused for a period of time, ensure there are no gas leaks and that the burners are not clogged.
- Keep power cables and inlet pipes away from hot surfaces.
- No flammable materials should be stored within 1 meter of the oven.
- In case of an uncontrolled fire, remove food from the flames until they are extinguished.
- If grease catches fire, close the gas valve and shut the door until the flames are completely extinguished.
- LPG is not the same as natural gas. It is dangerous to convert or use natural gas on an oven designed for LPG. Doing so will void the warranty.
- A rusty or damaged gas cylinder can be dangerous and must be checked by the supplier.
- Do not use cylinders with faulty valves.
- Do not place used gas cylinders near the oven. Containers that are not completely empty may contain combustible residues.
- This appliance is intended for professional use by qualified personnel.
- Do not allow children to approach or play near the oven when it is in operation.

ASSEMBLY AND INSTALLATION OF THE BASE

120 -130

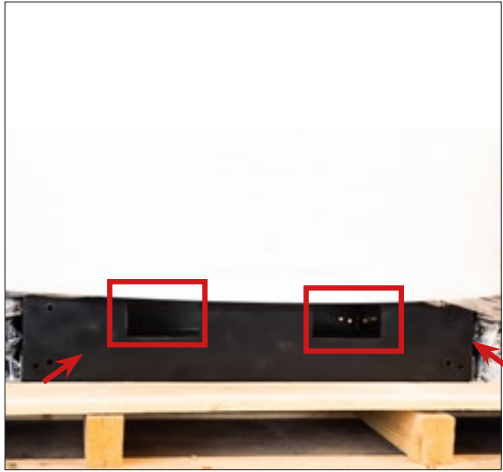

1 - Using a forklift, lift the oven by inserting the forks into the designated holes located on the bottom part.



2 - Before lifting the oven, remove the blocks located at the 4 corners that secure it to the pallet.



5 - After ensuring that the oven is lifted securely, proceed with attaching the feet to the four corners.



6 - After aligning the holes at the base of the oven with those on the support, insert and tighten the bolts with the nuts. Assistance from another person is recommended to carry out this operation.



3 - Pay attention to the maximum load capacity supported by the forklift.

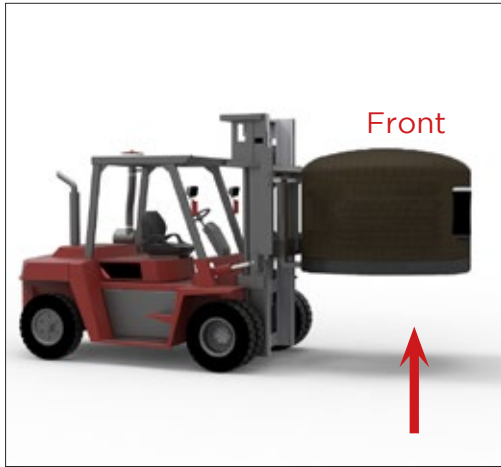

4 - Lift the oven to at least 1.5 meters in height to work comfortably during the base assembly.



7 - After carefully tightening each bolt, proceed with mounting the 4 support bars using the bolts and nuts.



8 - Once the base is installed, place the oven on the floor.

ASSEMBLY AND INSTALLATION OF THE BASE MODEL 90 and 150

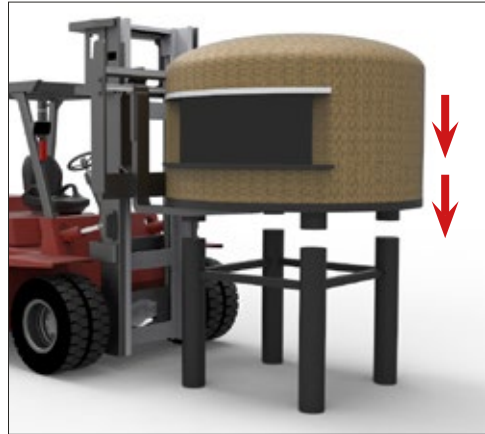

STEP 1

Lift the oven using a forklift if possible.
WARNING: CHECK THE MAXIMUM LOAD CAPACITY OF THE FORKLIFT. Depending on the model, the weight ranges from 1200 kg to 2200 kg.

STEP 2

Place the oven on the base and slowly bring the two parts together.

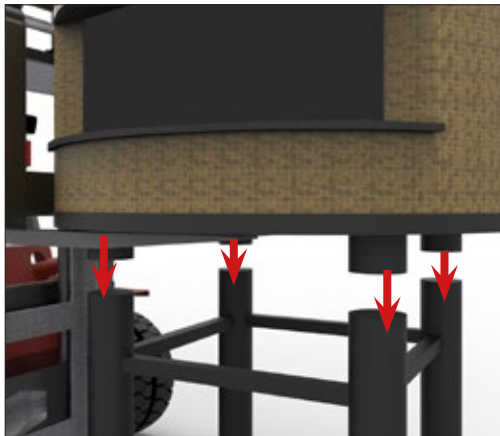

STEP 3

Align the oven's feet with the base structure.

15 KW BURNER MODEL 90

WARNING: Before turning on the oven, follow the instructions below.

- It is recommended to check all gas connections before using the oven.
- Do not lean over the oven during gas ignition; keep your face and body at least 50 cm away from the oven door.
- The oven mouth must be open during ignition.
- The gas control knob must be in the off position.
- Do not move the oven while it is in use.

1. To ignite the pilot flame, press and turn the knob to the spark symbol.

2. While holding down the burner knob, simultaneously press the igniter button to light the pilot flame.



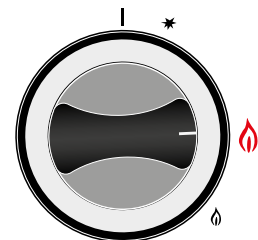
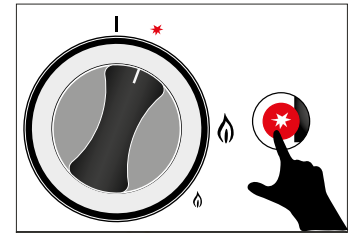
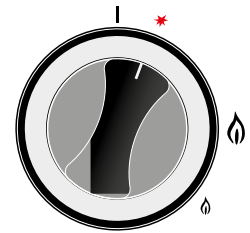

NOTE: Igniting the pilot flame for the first time, or after it has cooled down, may require several attempts due to air in the supply line. Please be patient.

3. Once the pilot flame is lit, you will see a small flame. You can now release the ignition button, BUT you must KEEP the burner knob pressed for 15 seconds. This ensures the thermocouple is hot enough to keep the pilot flame lit.



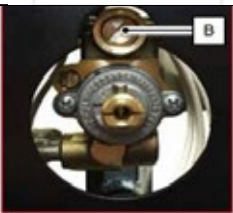

4. Release the burner knob and turn it counterclockwise to the largest flame symbol. The oven burner is now on high flame, and you can begin preheating the oven.



HIGH FLAME ADJUSTMENT M90-150

STEP	ACTION	IMAGE
1	Press and turn the selector knob counterclockwise.	
2	Set the selector knob to the "HIGH FLAME" symbol.	
3	Pull out knob "A" by gripping it with your fingers and firmly pulling it outward.	
4	Adjust the height of the high flame by turning screw "B": <ul style="list-style-type: none"> • turn clockwise to decrease the flame. The correct flame level is reached when the flame reaches the center of the oven dome.	
5	Check the flame color in relation to the airflow. The flame should be soft, quiet, and yellow in color, but it must not leave marks on the oven dome: <ul style="list-style-type: none"> • Natural gas: open the shutter to position 3.5/4. • LPG: open the shutter to position 5.5/6. 	
6	After completing the flame adjustment, reattach knob "A".	

LOW FLAME ADJUSTMENT M90-150

STEP	ACTION	IMAGE
1	Press and turn the selector knob counterclockwise.	
2	Set the selector knob to the "LOW FLAME" symbol.	
3	Pull out knob "A" by gripping it with your fingers and firmly pulling it outward.	
4	Adjust the height of the low flame by turning screw "C". The correct flow rate is achieved when the flame just touches the dome and the temperature of the empty oven does not increase.	
5	Check the flame color in relation to the airflow. The flame should be soft, quiet, and yellow in color, but it must not leave marks on the oven dome: <ul style="list-style-type: none"> • Natural gas: open the shutter to position 3.5/4. • LPG: open the shutter to position 5.5/6. 	
6	After completing the flame adjustment, reattach knob "A".	

FLAME AIR ADJUSTMENT M90-150

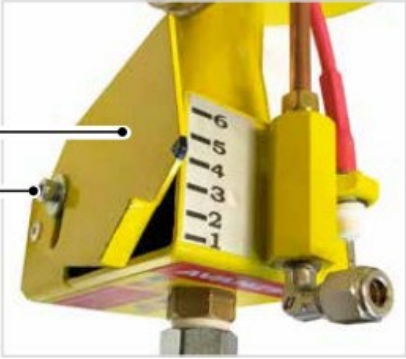

STEP	ACTION	IMAGE
1	The burner must be operating.	
2	Loosen Allen screw "1" on the flame air flow adjustment plate.	
3	Manually adjust plate "2" until the desired airflow is achieved.	
4	Check the flame color in relation to the airflow. NOTE: the flame should be blue at the base and yellow at the tip just enough to illuminate the oven, but without producing soot (which indicates an overly yellow flame).	

IMPORTANT!

The flame color is an indicator of the air-gas mixture ratio:

- A blue flame indicates an excess of oxygen.
- A yellow flame indicates a lack of oxygen.

IGNITION BATTERY REPLACEMENT

STEP	ACTION	IMAGE
1	Unscrew and remove the ignition button "A".	
2	Remove the old battery and insert a new one into compartment "B", making sure to respect the polarity.	
3	Screw in button "A".	
4	Dispose of the replaced battery properly.	

LPG - NATURAL GAS CONVERSION 15 KW

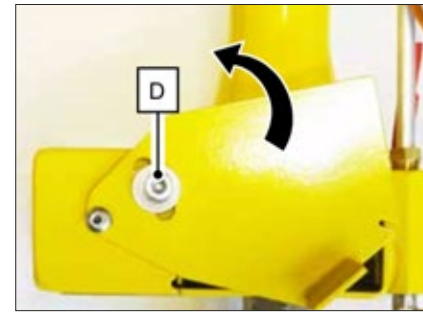

1 - Using a 4 mm Allen key, unscrew and remove screw "D" to allow the complete opening of the plate.

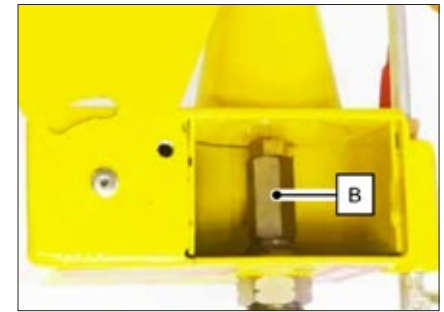

2 - Using a 13 mm wrench, unscrew and remove fitting "B" from the burner.

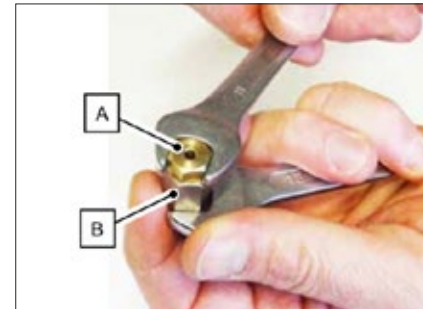

3 - Using an 11 mm wrench, unscrew nozzle "A" from fitting "B" and replace it with the supplied nozzle for the conversion.

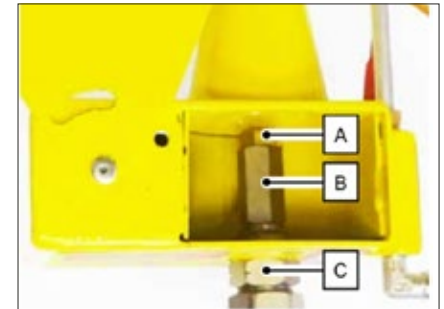

4 - Screw fitting "B" and nozzle "A" onto connector "C".

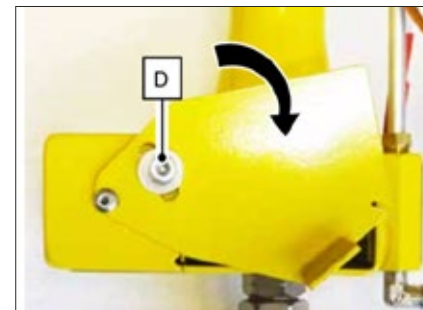

5 - Re-tighten screw "D" to secure the plate.



NAPOLI 15KW Burner

CONTROL UNIT ASSEMBLY



Control Unit:

- 1- 5-pin multipolar connector
- 2- 4-pin multipolar connector
- 3- Power plug
- 4- Temperature probe



1 - Place the control unit in the designated location indicated by the arrow in the image.



4 - Attach the probe locking bracket into the hole located under the oven on the left side, using two self-tapping screws.



5 - Insert the probe into the hole so that it protrudes 1 cm above the refractory surface.



2 - Once the burner is positioned and the holes are aligned, secure it using the 4 provided screws.

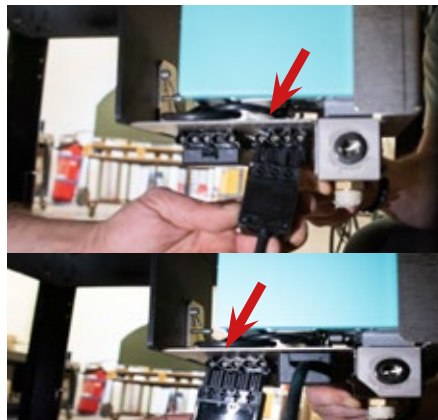

3 - Connect the two multipolar connectors to the sockets located at the back of the burner.



6 - Once the probe is inserted to the appropriate length, secure it by tightening the screw on the threaded part.

POSITIONING



WARNING: The outer walls of the oven can reach temperatures above 50 °C (120 °F). No flammable materials should be within a 1-meter radius around the oven.

CAUTION

Place the oven in a location sheltered from wind or strong drafts.

The built-in Napoli oven is available. For gas models, provide a ventilation and inspection grille for the burner.

FOR YOUR SAFETY

Place the oven on a flat and stable surface. Unintentional movement during operation may cause injury and property damage.

Never place firewood or flammable materials on the oven threshold.



CAUTION

Place the oven at a minimum distance of 20 cm (8 inches) from the wall or any other equipment. Allow a minimum distance of 50 cm (20 inches) for the installation of the smoke duct, depending on the model and insulation.

GAS BURNER ASSEMBLY



STEP 1

The refractory floor of the Napoli oven is already prepared to accommodate the burner. Looking under the oven, on the left side, you can locate the connection hole (A).



STEP 2

Insert the supplied sleeve (B) into the hole; this is necessary to connect the burner.

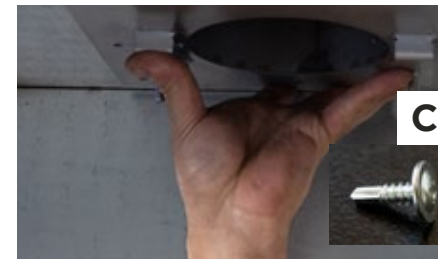

STEP 3

After positioning the sleeve, secure it to the structure using the provided self-drilling screws (C).



STEP 4

Use an electric screwdriver to drill into the structure and secure the sleeve in place.

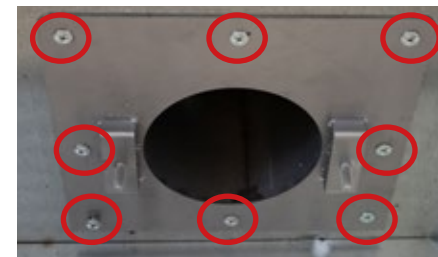

STEP 5

To complete the fastening of the sleeve, it will be necessary to install the 8 screws shown in the photo.

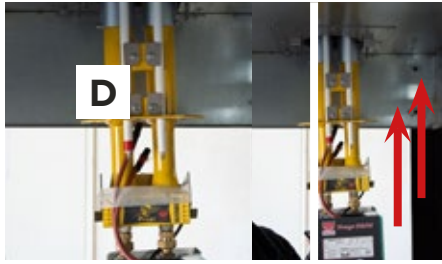

STEP 6

Insert the burner (D) into the sleeve you just installed. We recommend performing this operation with two people.



STEP 7

Use the supplied nut and washer (E) to secure the burner to the sleeve.

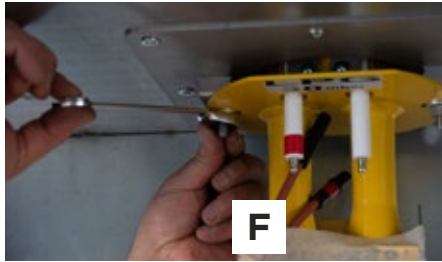

STEP 8

Use a 13 mm wrench to tighten the nuts.

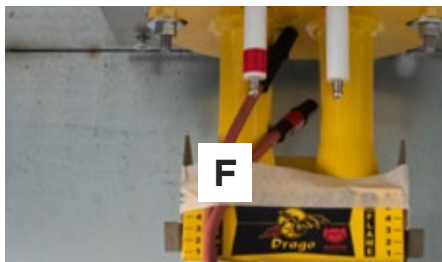

STEP 9

Once the two nuts with their corresponding washers are tightened, the burner is secured to the oven, and the electrical cables (F) can be connected to the control unit.

OVEN INSTALLATION

FROM A LEGAL STANDPOINT, THE SMOKE DUCT MUST SERVE ONLY ONE APPLIANCE. CONNECTING MULTIPLE OVENS TO THE SAME DUCT COULD COMPROMISE THE PROPER EVACUATION OF SMOKE.

Contact your local fire department to learn about any restrictions regarding the installation of the smoke duct or the inspection of the oven installation.

INDOOR SMOKE DUCT CONNECTION

For the Napoli oven to function properly, it must be connected to a smoke duct with a diameter of 250 mm (10 inches) and a minimum height of 4 meters (13 feet).

1. If existing ducts are insufficient, it is recommended to use stainless steel connecting pipes with an appropriate diameter and proper insulation.
2. Seal with materials resistant to high temperatures (450 °C to 840 °F).
3. This connection should avoid bends or deviations as much as possible, as they can hinder smoke evacuation.
4. Any bends must not exceed 45 degrees.
5. To prevent smoke backflow into the building, place the chimney cap at the highest part of the roof, fully exposed to the wind (anti-backflow caps).
6. Do not connect the duct to other pipelines.
7. The duct must be thermally insulated to avoid heat loss and allow smoke to rise.
8. All installation work must be carried out by a certified expert.
9. The following table indicates the correct duct diameter (D) according to its height.

H < 3 m	3 m < H < 5 m	H > 5 m
D 300 mm	D 250 mm	D 200 mm

Note: A butterfly damper, not included, can improve draft and smoke regulation.

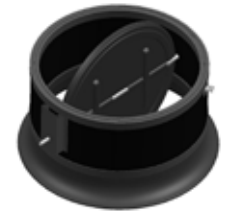

PYROMETER



- The pyrometer measures the temperature at a specific point inside the oven. The value indicated by the pyrometer is for reference only. With experience, you will better learn to assess when the oven is ready for different types of cooking. Gradually, you will master your oven and become very skilled at selecting the right cooking temperature. The Alfa Pro laser thermometer is available as an optional accessory on the website.

OVEN DOOR

If the fire is too strong and extends out of the oven opening, use the door to adjust the flame.

WARNING: This product has not been tested for use with the door. To reduce the risk of fire and injury, do not use the oven door.

Keep the oven door open when the fire is lit.

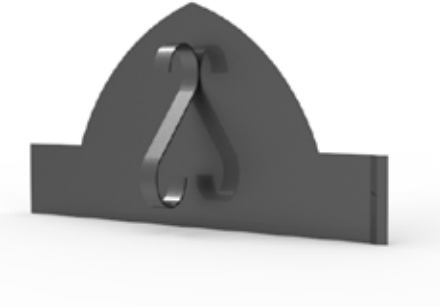

FIRE EXTINGUISHING

To extinguish the fire, close the oven door and wait for the ash to form. Ensure the oven is cool, then remove the ash using metal tools.

IGNITION

WOOD-FIRED OVENS

WARNING: Before lighting the oven, follow the instructions.

- Do not use flammable liquids or other fuels to start the fire.
- Ensure that no flammable materials are near the oven and that the minimum safety distance is observed.

IGNITION

- Make a small pile of dry kindling in the center of the oven.
- Once the fire is established, add two large logs and move the fire to one side of the oven.
- After a few minutes of continuous burning, the oven will reach a temperature of 400 °C (750 °F) by burning off the soot. The oven is then ready for cooking.



FIRE EXTINGUISHING

- To extinguish the fire, close the oven door and wait for the ash to form.
- After about 30 minutes, remove the ash.

DIFFERENT TYPES OF FIREWOOD



- Use small, dry wood to start the fire.
- Never use treated wood, resinous wood, or reclaimed wood for burning.
- Wet or damp wood may crack due to the water content.
- It will produce a lot of smoke and little heat.

FOR YOUR SAFETY

- Do not leave the oven unattended while the fire is starting.
- To maintain a constant temperature, add small amounts of wood at regular intervals. Do not continuously add logs to avoid a dangerous rise in temperature or flames coming out of the oven, which could harm people or damage objects.

IGNITION

GAS OVENS



STEP	ACTION	IMAGE
1	Press the red main switch located on the left side.	
-	The green display shows "OFF" and the red display indicates the oven's internal temperature.	
2	Press the red button to turn the burner on to the "ON" position. The green display shows the set temperature or zero.	

FOR YOUR SAFETY

- Do not close the door when the oven is running with the flame set to maximum.
- Never exceed the temperature limit of 500 °C (900 °F).
- Never disconnect the gas hose or any other fittings while the oven is in use.

CHANGE THE UNIT OF MEASUREMENT

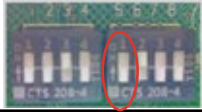
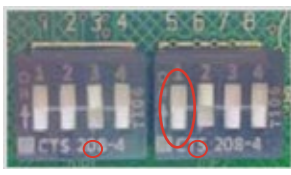
CELSIUS / FAHRENHEIT

STEP	ACTION	IMAGE
1	Turn off the power supply to the control unit using the main switch located in the room.	
2	Unscrew the 4 screws to open the Drago Control Plus control panel.	
3	At the back of the control panel, locate the terminal block.	
4	By adjusting LEVER No. 5, it is possible to change the temperature measurement unit: - Fahrenheit degrees (°F) are selected with the lever in the up position. - Celsius degrees (°C) are selected with the lever in the down position.	
5	Tighten the screws to reattach the cover of the Drago Control Plus control panel.	



IT IS STRICTLY FORBIDDEN TO REPLACE FUSES WITH WIRING OR OTHER CONNECTORS.

ADJUSTING TEMPERATURE AND FLAME

THE MAXIMUM ADJUSTABLE TEMPERATURE IS 450 °C.

WARNING

The cooking temperature setting F2 corresponds to the operating temperature of the oven.

STEP	ACTION	IMAGE
1	Press the temperature increase button until the desired temperature is displayed on the green screen. Note: It is rarely necessary to set the temperature above 360 °C.	
2	When the desired temperature is reached, release the arrow button. The Drago Control Plus stores the set temperature, which will blink on the green display.	
3	The green display stops blinking and the LED corresponding to the operation of the second flame lights up, thus turning on the second flame.	

GAS ADJUSTMENT 1 FLAME (F1)

Flame F1 is always on when the burner is operating, and it serves only two functions:

- Cooking pizzas in an already preheated oven
- Illuminating the inside of the cooking chamber.

Flame F1 must NOT heat the oven, as it is a "maintenance" flame. When the oven operates in F1 mode only, the temperature should not increase; instead, it should gradually decrease by about 7 °C, so that flame F2, if activated, can reignite, or the temperature can be maintained if the oven is empty. Flame F1 remains on and can be visually inspected: it forms a small mushroom shape reaching the start of the oven dome. The flame should be gentle, quiet, blue at the base, and yellow at the tip. You should aim for a flame that is as yellow and bright as possible but stop before soot deposits on the dome.

Flame F1 should only turn off in the following cases:

- The oven operator turns off the burner using the red "ON/OFF" button
- The temperature exceeds the set limit (factory set at 450 °C)
- Activation of the safety thermostat, negative pressure, or unsuitable environment.





The adjustment criteria for flame F1 are:

- Temperature increase (to avoid): adjust the gas regulation screw to reduce the flow
- Amount of light produced
- Soot (to avoid).



FIRST IGNITION

LOCK / UNLOCK THE BURNER

During the first ignition, the burner may go into safety lock.
In case of locking, the sequence is as follows:

STEP	ACTION	IMAGE
1	The display shows the message "bLoc" steadily. Note: the burner may attempt to start once before the "bLoc" message appears on the green display.	
2	Then, the burner's red lock LED turns on.	

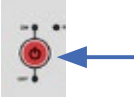
UNLOCKING THE BURNER VIA THE "RESET" BUTTON.

STEP	ACTION	IMAGE
1	Check that the green light on the ON-OFF button is on.	
2	Press the "RESET" button. Wait about 1 minute for the cycle to restart.	
3	If the problem persists, purge the gas line and then repeat the unlocking procedure. If the problem is not resolved, contact technical support.	

BURNER UNLOCKING

USING THE SIDE "MAIN SWITCH" BUTTON

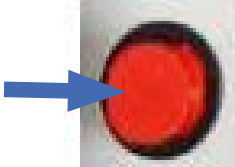
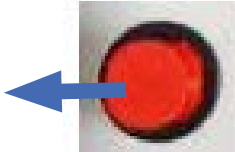
STEP	ACTION	IMAGE
1	Press the red "MAIN SWITCH" button (located on the left side) to cut off the burner's power supply.	
2	Press the red "MAIN SWITCH" button again (located on the left side) to restore power to the burner. The burner will restart automatically.	
3	If the problem persists, purge the gas pipe and then repeat the unlocking procedure. If the issue is not resolved, contact technical support.	

BURNER 34 KW

NAPOLI OVEN MODEL M120 - M130

EASY BURNER COMPONENTS

1. Control equipment
2. 7-pin multi-connector
3. Fuel solenoid valves
4. Pressure port
5. First flame regulator
6. First flame pressure port
7. Second flame pressure port
8. First flame air regulator
9. Second flame air regulator
10. Flame ionization cable
11. Flame ignition cable
12. Flame ionization electrode
13. Flame ignition electrode



LIST OF CONTROL UNIT FUNCTIONS

1. Burner ON/OFF switch.
2. Mode selection button: Manual (M).
3. Mode selection button: Automatic (A).
4. Button to increase the programmed temperature.
5. Button to activate/deactivate the booster function.
6. Button to manually turn the second flame ON or OFF.
7. Button to decrease the programmed temperature.
8. LED indicator for first flame mode.
9. LED indicator for the operation of the second flame (F2).
10. LED indicator for faulty temperature probe.
11. LED alert for burner lockout.
12. Reset button to unlock the burner.
13. Red display showing the internal temperature measured by the probe and error messages.
14. Green display showing the programmed cooking temperature and control unit information.
15. Main switch.



LPG-NATURAL GAS CONVERSION

NAPOLI 34 KW GAS BURNER

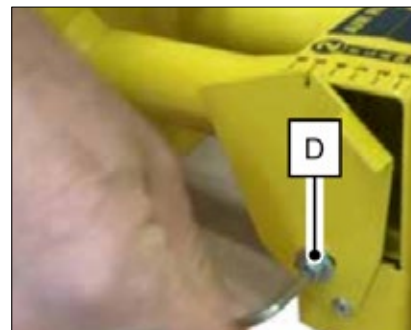

STEP 1 - Loosen and remove screw "D" to completely remove the partition.

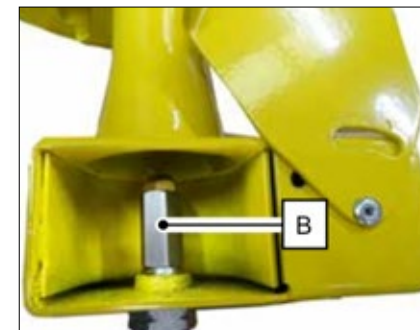

STEP 2 - Remove the locking screw "B" and take it out of the burner.

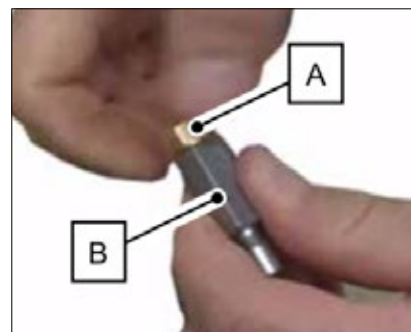

STEP 3 - Unscrew nozzle "A" from locking screw "B", and replace the nozzle according to the type of gas. Always follow the specifications for flame 1 and flame 2.

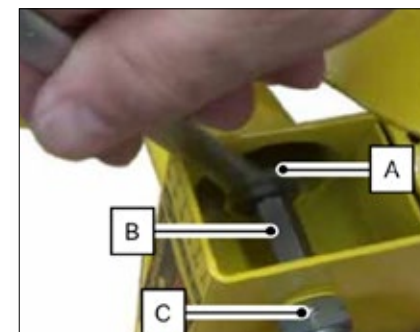

STEP 4 - Fasten locking screw "B" and nozzle "A" to fitting "C".

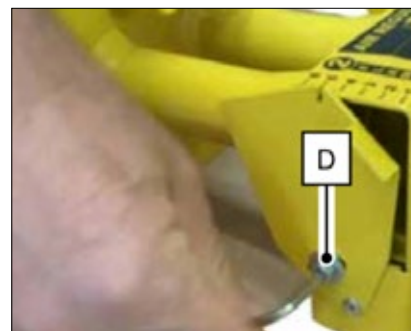

STEP 5 - Tighten screw "D" to secure the partition. The position of the partition regulates the combustion air, so be careful to reposition it correctly.



NAPOLI 34KW GAS BURNER

REPLACEMENT OF THE FLAME SEPARATOR

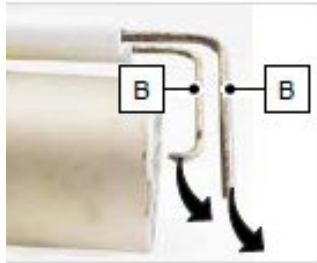

1 - Remove the burner from the oven.

2 - Rotate the two electrodes "B" outward to facilitate the removal of the flame arrestors.

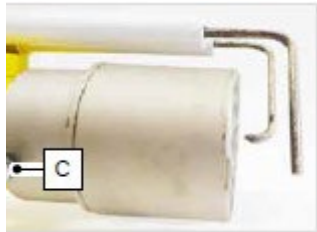

3 - Loosen the Allen screws (4 mm) located on the sides of the flame separator, taking care to note their position for reassembling the new separator.

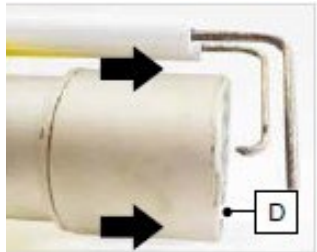

4 - Remove the flame separator "D" by sliding it out.

5 - Reassemble the flame arrestors by performing the steps in reverse order, paying close attention to the correct repositioning of the ignition/detection electrode.

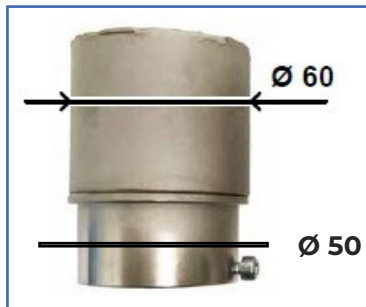

GPL Ø 50

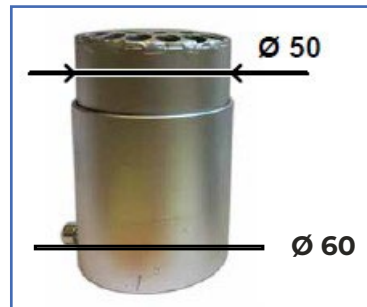

METHANE Ø 60





34 KW BURNER INSTRUCTIONS FOR USE OF THE CONTROL UNIT

- Turn on the Easy Control unit by plugging the blue connector into a 220 V IEC socket, 16 A, 50 Hz. The displays light up; the red one shows the internal temperature of the oven, while the green one shows the set temperature. At the first startup, 0 °C appears on the screen. To ignite the burner in first flame mode, press and hold the SET button (No. 3) for 3 seconds. The green display will flash and show 10 °C; by pressing the button (No. 4), you can increase the temperature of the first flame to the desired value; releasing the button saves the temperature. Then, the display will automatically show the temperature of the second flame, which will be 0 °C at first ignition. To light the burner, press the ignition button (No. 1); after a few seconds, the spark will ignite the first flame and the corresponding LED (No. 6) will turn on.
- In case of first ignition, the burner may lock; the corresponding LED (No. 9) lights up. To unlock it, press the RESET button (No. 10). The selector must be set to position A (automatic) to avoid unintended ignition of the second flame. To automatically ignite the second flame, simply press the button (No. 4); the desired temperature will appear on the green display and be saved. When the LED (No. 7) lights up, the second flame is active.
- Keep in mind that the temperature of the first flame must always be higher than that of the second flame; the preset difference in the control unit is 10 °C.
- Note that when the set temperature for the first flame is reached, the burner switches off, corresponding to the maximum achievable temperature.
- The set temperature for the second flame corresponds to the operating temperature of the oven allowing the burner to work with two flames. When the set temperature of the second flame is reached, only the first flame remains lit.
- This situation occurs when the heat supplied by the burner with the first flame matches the heat required by the empty oven to maintain the temperature of the first flame in other words, the temperature should neither increase nor decrease.





INSTRUCTIONS FOR USING THE BOOSTER BUTTON

The “Booster” function activates the operation of the second flame F2 when the oven has reached the set temperature and has then turned off. Once the programmed time for the “Booster” function has elapsed, the second flame F2 resumes automatic operation. The Booster function can only be activated once the oven has reached the set temperature and the second flame F2 has turned off. The second flame F2 will not restart until the oven temperature has dropped by 7 °C; it is within this 7 °C range that the Booster function can be activated. The following procedure allows programming the duration of the “Booster” function.

STEP	ACTION	IMAGE
1	Press the “Booster” button.	
2	The programmable time for the Booster function appears on the green display.	
3	Press the “+” and “-” buttons to increase or decrease the duration of the “Booster” function in 30-second increments.	 
3A	Once the function is activated, the second flame F2 starts operating; therefore, the preset cooking temperature may be exceeded.	
4	If necessary, deactivate the Booster function by holding down the “Booster” button for a few seconds.	

MANUAL/AUTOMATIC FUNCTION

STEP	ACTION	IMAGE
1	Press the “M” button, meaning manual mode, to keep flame F2 continuously lit regardless of the programmed temperature.	
2	Press the “A” button, meaning automatic mode, to reactivate the automatic ignition and turn off flame F2.	

ERROR MESSAGES

COMMUNICATION	IMAGE
BLOC: Burner lockout: after three attempts, the burner did not ignite.	bLoc
<ul style="list-style-type: none"> Check that all gas valves on the piping are fully open. Verify that the ignition cable is connected to the burner control equipment (Sit), the ignition electrode, and the detection electrode on the burner. Check the integrity and position of the ignition and detection electrodes on the burner and replace them if necessary. Replace the EV1 coil. Reverse the phase and neutral wires on the blue power plug of the Drago Control panel if the system is ungrounded. 	
AL01: Sensor fault	AL01
<ul style="list-style-type: none"> Check that the probe is properly inserted into its designated hole. Replace the temperature probe of type "J" (0° to +550°C). 	
HUOL: High voltage detected at the outlet where the Drago Control panel is connected.	HUOL
<ul style="list-style-type: none"> The limit voltage is 250 V; Test and connect the Drago Control control panel to another socket or contact an electrician. 	
LUOL: Low voltage on the socket to which the Drago Control control panel is connected.	LUOL
<ul style="list-style-type: none"> The voltage limit is 250 V. Test and connect the Drago Control control panel to another outlet, or contact an electrician. 	
AL02: Failure of the Drago Control panel	AL02
<ul style="list-style-type: none"> Remove and then reconnect the IEC (blue) plug into the power socket. 	
COMMUNICATION	IMAGE
---- (4 LINES): sensor fault.	----
<ul style="list-style-type: none"> Replace the temperature sensor. 	

34 KW BURNER ELECTRICAL DIAGRAM

ELECTRICAL CONNECTIONS

The power supply line must be interrupted by a 10 A double-pole circuit breaker with a 2 A fuse.

The connection cables to the burner's multipolar connector must have a cross-section of at least 1.5 mm² and comply with IEC 20-22 standards.

The burner must be grounded according to applicable laws.

Do not reverse the phase and neutral wires.

Hot parts of the oven must be kept away from electrical lines.

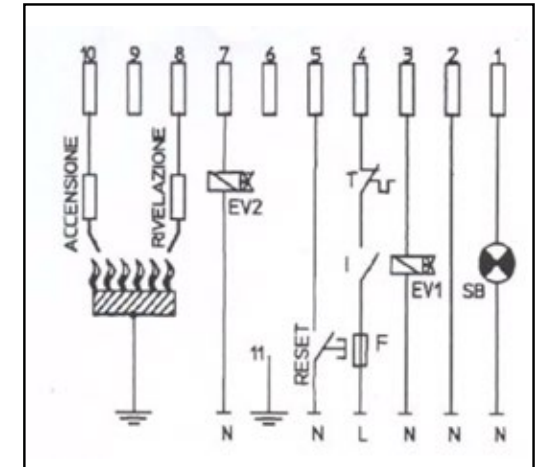

EASY CONTROL UNIT WIRING DIAGRAM

- L** = Line (Phase)
- N** = Neutral
- 1** = Burner phase
- 2** = Burner neutral
- 3** = Reset
- 4** = Lockout
- 5** = Phase for second flame solenoid valve
- 6** = Return for second flame solenoid valve
- P** = Bridge for manual use
- / +** = Thermostat probe
- O** = Automatic / manual selector

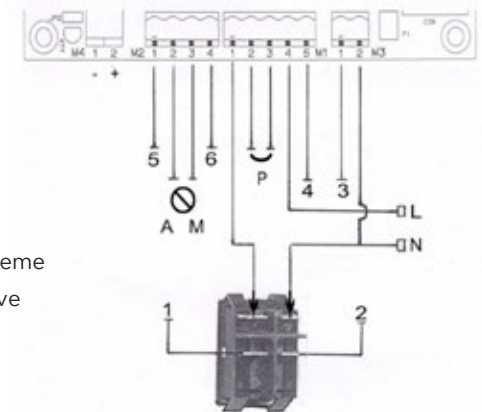

NETTOYAGE ET ENTRETIEN



Chimney Flue

Before lighting the fire, make sure the chimney flue is not blocked (it should be inspected and cleaned once a year).



No Chemicals

Never use chemical products to clean the oven.



Ash Cleaning

Remove the ashes from the previous cooking using a brush and a shovel.



Never clean the oven when the floor is hot.

Do not wipe the oven floor with a damp cloth, as this could cause it to crack.



Cleaning the Oven Floor

When the oven is cold, clean the floor with a brush and wipe it with a damp cloth.

WARRANTY



ALFA professional ovens are covered by a legally-required 12-month warranty against conformity defects. Good maintenance and proper use of the product will contribute to extending its lifespan.

The time limit for reporting defects is 8 days from their discovery.

For legal warranty regulations, please refer to the provisions of the individual national legislation of reference.

YOU ARE REQUESTED TO KEEP THE PURCHASE RECEIPT OR INVOICE TO SHOW TO THE RETAILER. WE ADVISE YOU TO WRITE DOWN BELOW THE SERIAL NUMBER YOU WILL FIND ON THE IDENTIFICATION LABEL ON THE BACK OF THE PRODUCT.

In case of any warranty claims, please contact your dealer only. Under the Warranty, ALFA undertakes to remedy any faults and malfunctions which are demonstrably related to material or manufacturing defects. ALFA shall be entitled to decide, on a case-by-case basis, whether to repair the product, to replace it or to substitute defective parts, without prejudice to business agreements and national legislation of reference.

We recommend the exclusive use of ALFA branded spare parts

The warranty does not cover the following:

Damage caused by the carrier in the event of such damage not being indicated immediately on the transport document by marking the product "accepted with reservation" upon receipt and immediately contacting the seller for further clarification;

The case of the oven not being properly used and installed as described in this manual. In particular, in the event of the oven needing to be recessed at the time of installation, please follow the correct procedures indicated in this manual under penalty of invalidating the warranty;

The case of the oven being tampered with in any way, whether intentionally or unintentionally, or altered so it is no longer in the condition it was when the product was delivered;

The case of damage to the product due to obstruction of all smoke/fume outlets;

Failure to observe the proper product maintenance and cleaning instructions as set out in the manual;

Damage to the burner due to cooking residues or damage in cases where fuel other than that recommended has been used, e.g. use of liquid barbecue charcoal, chemicals or other fuel;

The case of components being used which have not been manufactured or recommended by Alfa;

The case of damage being the result of the use of chemicals inside or outside the oven;

Damage due to exceeding the temperature indicated by the pyrometer

provided, over 500°C (932° F), due to improper use of wood fuel;

The case of the label on the back of the product being removed, altered or erased;

The case of normal wear and tear of the product due to professional use;

Possible oxidation of the steel due to exposure to saline environments or near the sea.

Alfa specifies that possible oxidation is not due to quality defects in the product, but to intrinsic chemical-physical characteristics of steel in the event of prolonged exposure near saline environments;

Possible deterioration of the paint due to prolonged contact with flames;

Small surface imperfections on painted or aesthetic parts that do not affect the normal use of the product;

Accessory parts supplied with the product, such as the door;

Floors and underfloor insulation are not covered by the warranty. Alfa ovens are however supplied with a replacement floor;

As regards electrically powered products, the warranty does not cover light bulbs and any damage due to over voltage or the use of a power supply with inadequate power output and/or voltage;

The cost of the labour required to carry out the work under warranty.

