

ALFA**NAPOLI M120****Data Sheets - Scheda Tecnica****Gas**

FRNAPO-G120

Weight Peso	2140 kg 4717 lbs
Base weight Peso base	45 kg 99,2 lbs
Cooking floor Piano Cottura	Ø 120 cm Ø 47,2 inch
Max oven temperature Temperatura massima	500°C 932°F
Heating time Minuti per scaldare	120 min
Pizza capacity Numero Pizze	5 33cm
Heat capacity Potenza nominale	34 Kw 120000 BTU
Smoke temperature Temperature fumi	410°C 770°F
Volumetric flow Flusso volumetrico	28,92 g/s
Suction flow rate Portata aspirazione	1200 mc/h

Materials Materiali	Refractory brick, fiber ceramic, mosaic Mattone refrattario, fibrocera mica, mosaico	
Type of refractory Tipo di refrattario	Alumina silicate HeatKeeper™ Firebrick Tavella HeatKeeper™ silico-alluminoso	
Electrical connections - Collegamenti elettrici		
N° phases N° fasi	1	
Voltage Tensione	230 V	
Frequency Frequenza	50-60 Hz	
Absorption Assorbimento	25 Watt	
Recommended fuel Combustibile consigliato	LPG gas G30/G31 Gas GPL G30/G31	Natural Gas G20 Gas Metano G20
Gas category Categoria gas	I3+GPL	12H METANO
Operation Funzionamento	28..30/37mbar - 11W.C.	20mbar - 4 W.C.
Max consumption Consumo Massimo	2,3 Kg/h	3 mc/h



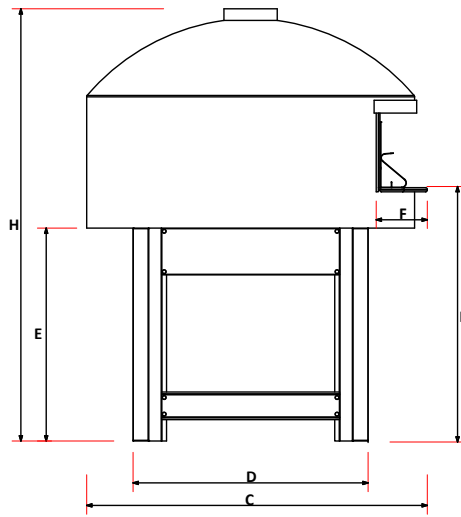
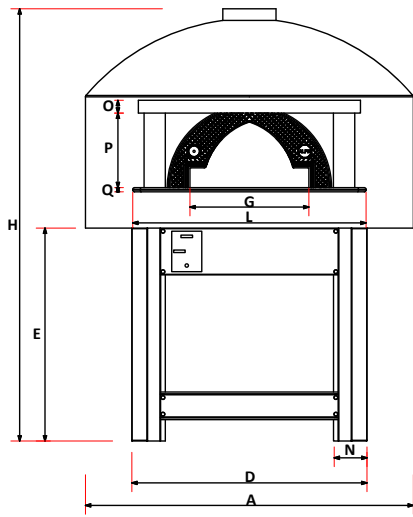

	cm	inch		cm	inch
A	154	60,6	M	25	9,8
B	120	47,2	N	15	5,9
C	160	62,9	O	6	2,3
D	110	43,3	P	35	13,7
E	100	39,3	Q	2	0,78
F	24	9,4	R	119	46,8
G	56	22			
H	203	79,9			
L	109,5	43			

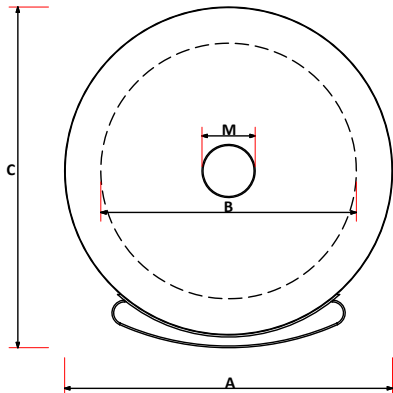

OVEN PACKAGING N120					
Dimensione imballo forno N120					
	Width Larghezza	Depth Profondità	Height Altezza	Packaging weight Peso imballo	Weight Peso
cm	175	175	140	Kg	90
inch	68,9	68,9	55,1	lbs	198

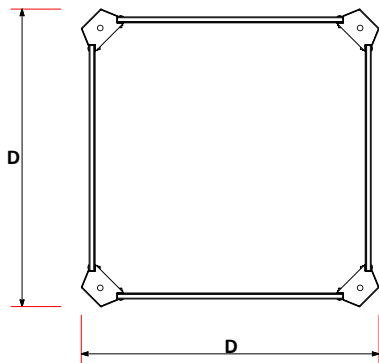

	cm	inch
N	15	5,9
D	110	43,3
E	100	39,3

Description Descrizione	Code Codice
Thermometer Termometro	YT50200
Door Sportello	SPT01000100
Kit gas Kit gas	GPL DIFGAS-EASY
	N.G. DIFMET-EASY
Drago D2 control unit Centralina Drago D2	DRAGOCON
Drago D2 probe Sonda Drago D2	C32SOND-D2

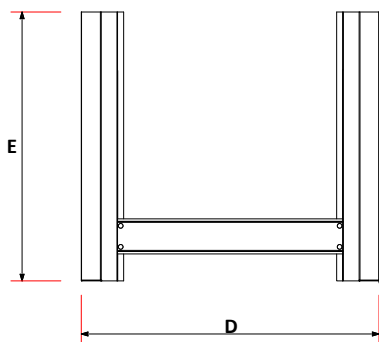

- Cupola e cappa esterna in mattoni sagomati a mano
- Rivestimento esterno personalizzabile a richiesta
- Stand di supporto in ferro rinforzato removibile
- Piano cottura in cotto refrattario Alfa
- Archetto in ghisa Alfa
- Davanzale in pietra lavica da 2 cm
- Disponibile a gas o a legna

- Dome and external hood in hand-shaped bricks.
- Oven floor made of Alfa's "cotto" refractory bricks.
- External coating customizable on demand.
- Removable supporting stand in reinforced iron.
- Alfa's cast-iron arch.
- 2 cm (0,8 in) lava stone landing.
- Available in wood or gas-fired options